

Rogue Audio Zeus

Vacuum Tube Dual Mono Power Amplifier



Owner's Manual

Rogue Audio, Inc.
3 Marian Lane
Brodheads ville, PA 18322

ISSUE DATE: 05/17/10

TABLE OF CONTENTS

1) Introduction	3
2) Unpacking the Zeus power amplifier	3
3) Connecting Zeus to your system	4
4) Operation of the amplifier	5
5) Setting the tube bias	6
6) Troubleshooting	8
7) Registration card	9
8) Fuse values	9
9) Specifications	9
10) Warranty	10

INTRODUCTION

Congratulations on your purchase decision! We at Rogue Audio truly believe that our amplifiers provide the “smartest” value in high-end audio. If you have never owned a vacuum tube amplifier you will be thrilled by the silky-smooth sound and incredible detail that only a tube amplifier can provide. And with the Zeus amplifier, you can be sure that you are getting the very best in tube amplification. We at Rogue Audio are extremely proud of our products and want you to enjoy them to their fullest potential. So please, take the time to read through this short manual so that you can be confident that you have set up your amplifier properly.

UNPACKING THE ZEUS POWER AMPLIFIER

Tools required: none

WARNING - This amplifier uses voltages that could cause injury or death. Never open the amplifier while it is plugged in, and always wait at least one hour after turning the unit off to unplug and open the unit. *Lethal* voltages can remain in the electronics after the unit is unplugged.

The Zeus amplifier has been painstakingly inspected for cosmetic flaws during and after assembly. In order not to damage the cosmetic appearance of your amplifier it is important that you follow the unpacking instructions carefully.

1. Carefully lift the outer box up and over the amplifier.
2. Remove the foam pads from the top of the amplifier
3. The Zeus has two built in handles on either end of the amplifier. Remove any rings or jewelry that can scratch the aluminum finish. **CAUTION – The Zeus amplifier weighs 200 pounds.** Carefully lift the amplifier and move it to its operational location. Note – this is not a one person job!
4. Save the packing materials. The packing materials and box have been carefully designed to protect your valuable equipment during shipping so you don't want to throw them away.
5. *Align Tubes* - Using a glove or a clean dry cloth, straighten any tubes that may have tilted during shipment. Ensure that all of the tubes are fully seated in their ceramic sockets.

CONNECTING ZEUS TO YOUR SYSTEM

Connecting Zeus to the Loudspeakers:

The rear panel has binding posts for both 4 and 8 ohm loudspeakers. The 4 ohm taps are those located closest to the center of the amps rear panel. The 8 ohm taps are located nearest the sides of the rear panel.

In general, if your speakers are rated at less than 6 ohms, use the 4 ohm taps and use the 8 ohm taps if they are 6 ohms or greater.

Connecting Zeus to the preamplifier:

There are three types of input connections on the rear panel of Zeus:

- 1) Fully balanced XLR type input.
- 2) RCA input
- 3) Balance RCA input (labeled "low Z")

For lowest noise levels, we recommend using either the balanced or "low Z" inputs. If you have a preamp with a high output impedance you may choose to use the standard RCA inputs to achieve proper bandwidth.

Note that if you have a variable output CD player you can drive the Zeus with it directly.

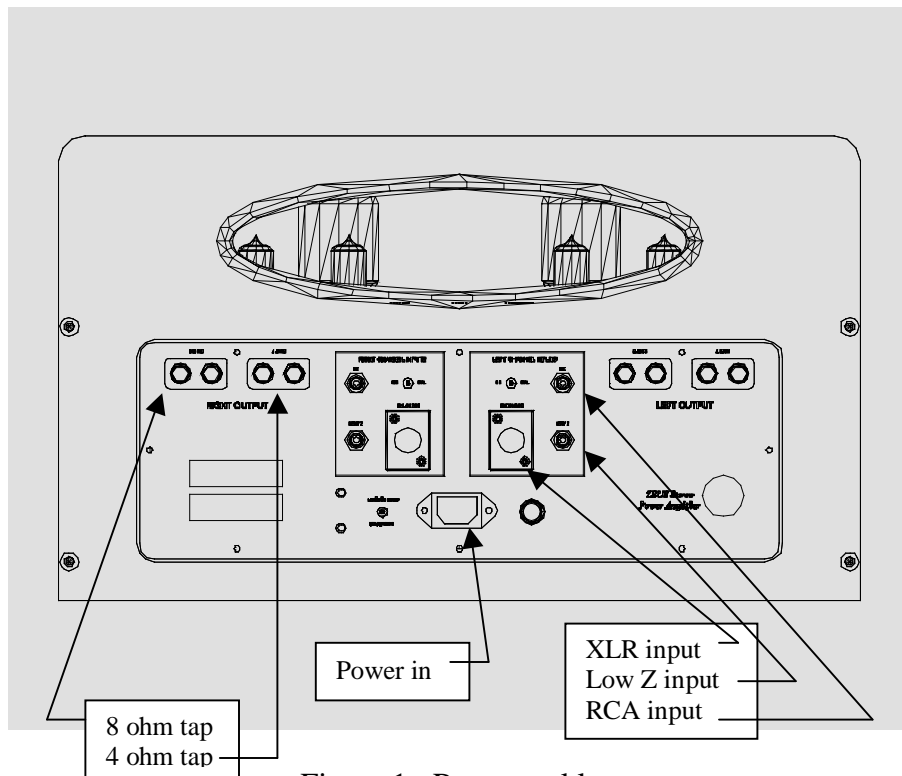

Figure 1. Rear panel layout

Connecting Zeus to the power outlet:

Your Zeus amplifier has been provided with a high ampacity power cord. Use this cord to connect the amplifier to the wall outlet. It is recommended that you use the same outlet as the preamp to avoid creating a ground loop. It is also recommended that you do not use a power conditioner as it may limit the current available to the amplifier.

OPERATION OF THE AMPLIFIER

After all proper connections have been made, you are now ready to turn the Zeus amplifier on. The power on/off switch is located on the front top of the amp between the triode/ultralinear and standby switches. Some preamplifiers and sources can generate dangerous transients that can damage loudspeakers. To avoid letting dangerous transients reach your loudspeakers turn your system on in the following order:

- 1) Turn on all sources (CD, tuner, etc.) that you will be using.
- 2) Turn on the preamplifier.
- 3) Wait until preamp has stabilized.
- 4) Power up Zeus amplifier
- 5) Select listening source and play music

When powering down your system turn the amplifier off first.

Note – **Important!** After turning off the amplifier, wait at least one minute to turn it back on. Do not turn it on then off and then on again in quick succession. Doing this will not allow the power supply to discharge between on/off cycling and may result in transient noises. If short term on/off cycling is necessary, restart the amp in standby mode.

Triode/Ultralinear switch:

The output transformer of a tube amplifier acts as the electrical interface between the very different impedances of the loudspeaker and the tube circuitry. There are three fundamental ways that the output transformer can be connected to the tube circuit.

- 1) Tetrode or Pentode connection – In this configuration, the highest power level is achieved but at the expense of significantly higher distortion levels. Practically speaking, this mode of operation is sonically inferior and has been disregarded in the Zeus design.
- 2) Triode connection – With this configuration, the lowest level of distortion is achieved but at the expense of output power. In the case of the Zeus, its power

level in triode is high enough that it will likely provide plenty of power for almost any speaker load.

- 3) Ultralinear operation – With this configuration, power levels near those of tetrode mode are achieved with low distortion levels that approach those of triode operation. For loudspeakers that demand very high levels of power, ultralinear should provide excellent sound and plenty of power.

The triode/ultralinear switch allows the user to operate Zeus in either of the two modes. In general, the sonic differences are subtle but for a given loudspeaker one mode is likely to sound better than the other. There is a complex relationship between the output transformer and the crossover network so try both and see which one works best in your system. This switch can be operated while the amplifier is playing but you will hear a small relay noise through the loudspeaker.

Standby Switch:

The Zeus amplifier **SHOULD NOT BE LEFT RUNNING WHEN NOT IN USE**. Unlike solid state amplifiers, tube amplifiers **should be shut down when not being used**. This will greatly prolong tube life.

A standby switch has been provided for short-term use between listening sessions so that the amp will remain in a “warmed up “ state. If you will not be listening to the amplifier for more than an hour, it is advised that the amplifier be turned off. The standby switch lowers the voltage on the tubes and heater filaments to ½ of normal operating voltage. Some output (distorted) will be heard so the source material should be turned off when in standby mode.

SETTING THE TUBE BIAS

Tools required: bias tool (provided with amplifier)

The output tubes (the big ones) need to be “biased’ with a grid voltage that controls the flow of electrical current through the tube. Tube biasing on the Zeus amplifier has been designed to be both simple and effective. On some amplifiers biasing is done for two or more tubes simultaneously. With this method, the total current flowing through the group of tubes may be correct, but the current flow through any individual tube may vary significantly from the optimal value. With the Zeus amplifier the bias is set individually for each tube so that the correct operating point is assured. An added benefit to this approach is that, should a tube fail prematurely, the single tube can be replaced without having to purchase a matched set. Use the following procedure to set the tube bias:

WARNING – There are dangerous and potentially lethal voltages inside this amplifier. Do not touch any part of the amplifier other than as described below. If you are uncertain about any of these instructions, please contact your dealer and have them bias the amplifier for you.

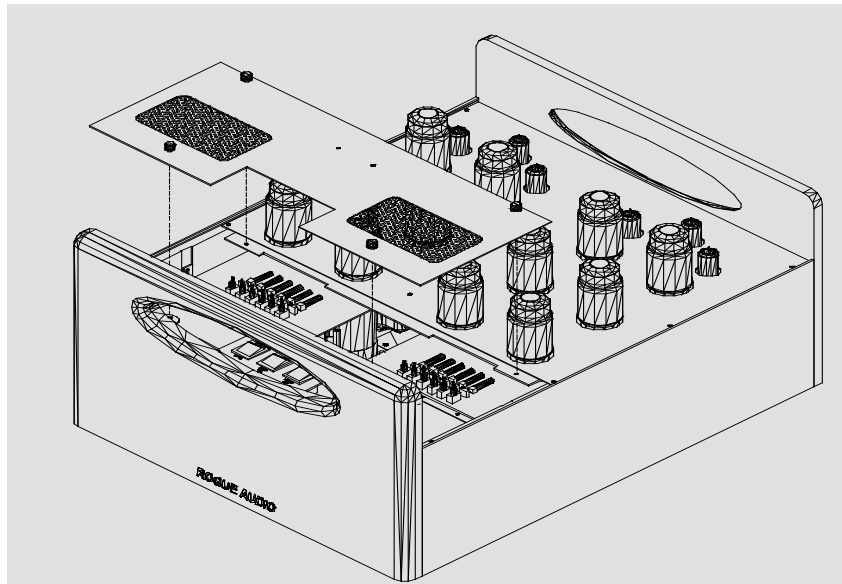

Figure 2. Removable hatchplate

- 1) Allow the amplifier to warm up for at least 30 minutes.
- 2) Turn the preamplifier off so that no signal is entering the amplifier
- 3) Loosen the 4 captive screws on the top hatch cover.
- 4) Remove the hatch cover. The bias tool is snap attached to the inside of the cover.
- 5) Locate the toggle switches and associated small potentiometers (they are blue and have a small screw in the top). There is a set of six for each of the left and right channels. Note the biasing meter for each channel
- 6) Make sure that all of the toggle switches are pointed towards the rear of the amplifier. Begin with either channel and starting from the left, flip the first toggle switch towards the front of the amplifier. You will see that the meter will rise up to show that the tube's current is now flowing through the meter.
- 7) Using the bias tool, slowly turn the screw on the potentiometer that is adjacent to the switch until the bias meter reads 40 miliamps (mA). Turn the screw clockwise to lower the bias and counterclockwise to raise the bias. Note that there are two ends on the bias tool. Using the end with the recessed screwdriver will greatly facilitate this operation.

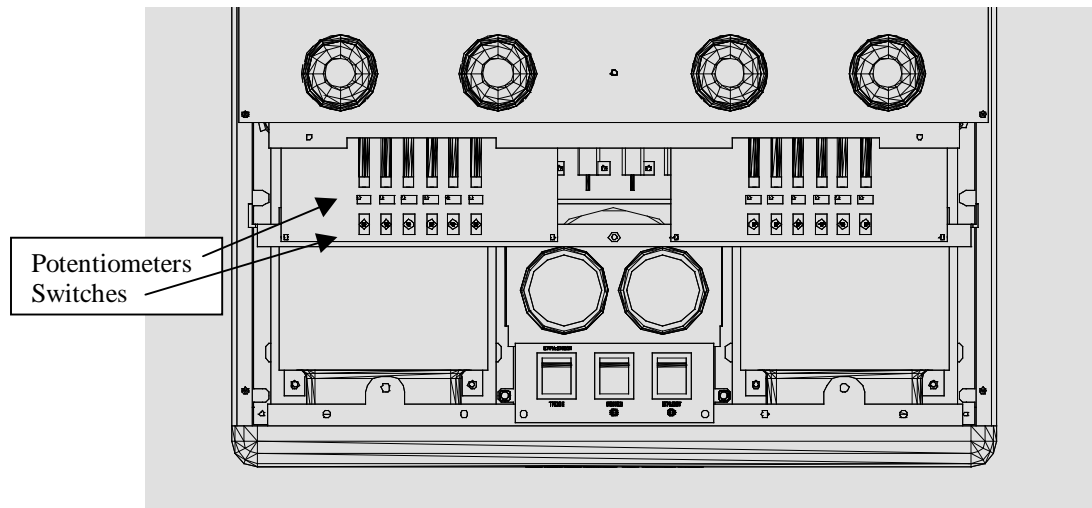

Figure 3. Bias switches and potentiometers

- 8) Flip the switch towards the rear of the amp thus disengaging the tube from the meter circuit.
- 9) Repeat the above steps for each of the tubes in both channels.

As it is a quick operation, the tube bias should be checked on a regular basis.

TROUBLESHOOTING

Speaker Hum – If hum can be heard from more than a few inches from the loudspeaker, there is probably a ground loop. Try using the “low Z” RCA jacks. If there is still hum, flip the grounded/ungrounded switch on the rear panel to ungrounded. If this fails to cure the hum, call customer service at Rogue Audio for further advice.

Tube will not bias – If the meter provides a reading but the tube will not bias, the tube is probably bad. If no meter reading can be attained, check the fuse (1/4 Amp slow blow). If the fuse is bad, replace the fuse and then set the bias. If the bias will not maintain itself and the fuse blows again, the tube should be replaced.

OWNER AND WARRANTY REGISTRATION FORM

Included with this manual is an Owner and Warranty Registration Form. Please take a minute to fill out this card and return it to Rogue Audio. This card must be returned within 30 days of purchase to validate the warranty.

FUSE VALUES

Main fuse located on rear panel (1) – 10 Amp slow blow (5 Amp slow blow for 220V-240V operation)

Tube Fuses (12) – ¼ Amp slow blow

Power supply fuses (2) – 1½ Amp slow blow

SPECIFICATIONS

output power	225 WPC
frequency response	10Hz - 100 kHz typical 20Hz-20KHz at full output
THD	< 0.1%
input sensitivity	1.0 V RMS
dimensions	19" W x 24" D x 12" H
weight	200 pounds (90Kg)
shipping weight	225lbs (101Kg)
power requirements	115/230V - 50/60Hz (15A service)

LIMITED WARRANTY

Warranty Period

This product has been manufactured under the highest standards of quality and workmanship. Rogue Audio Inc. (hereinafter "Rogue Audio") warrants this product against defects in material or workmanship as follows:

With the exception of vacuum tubes, Rogue Audio warrants to the original purchaser of this product all parts of this product against defects in material and workmanship for a period of three years from the date of retail purchase. Rogue Audio warrants the vacuum tubes for a period of six months from the date of retail purchase. Any defective parts will be replaced free of charge, excluding shipping and handling.

Proof of purchase in the form of a bill of sale or recited invoice which indicates that the product is within the warranty period must be presented to obtain warranty service. Rogue Audio suggests that the purchaser retain the dealer's bill of sale as evidence of the date of retail purchase.

What's Not Covered

This warranty does not cover cosmetic damage or any damage that results from product misuse, product abuse, installation error, connection to an improper voltage supply, accident, improper maintenance, alterations, modifications not authorized in writing by Rogue Audio, lightening, power surges, or acts of God. Use of any other than Rogue Audio factory parts may void this warranty.

This warranty does not cover the cost of parts and labor which would be otherwise provided without charge under this warranty, obtained from any source other than Rogue Audio.

This warranty applies only to consumer use of this product and does not cover any product that is used in any trade or business, or in an industrial or commercial application.

This warranty applies only to the original purchaser of this product when purchased from an Authorized Rogue Audio dealer.

This warranty is valid only in the United States.

YOUR RIGHTS

ROGUE AUDIO LIMITS ITS OBLIGATIONS UNDER ANY IMPLIED WARRANTIES UNDER STATE LAWS TO A PERIOD NOT TO EXCEED THE WARRANTY PERIOD. SOME STATES DO NOT ALLOW LIMITATIONS ON HOW LONG AN IMPLIED WARRANTY LASTS, AND SOME STATES DO NOT ALLOW THE EXCLUSION OR LIMITATION OF INCIDENTAL OR CONSEQUENTIAL DAMAGES, SO THE ABOVE LIMITATIONS OR EXCLUSIONS MAY NOT APPLY TO YOU. THIS WARRANTY GIVES YOU SPECIFIC LEGAL RIGHTS, AND YOU MAY HAVE OTHER RIGHTS WHICH MAY VARY FROM STATE TO STATE.

To Obtain Service

To obtain service, you must contact Rogue Audio and obtain a return authorization number. The product must be delivered to Rogue Audio in its original packaging prepaid at the following address:

**Rogue Audio Inc.
3 Marian Lane
Brodheads ville, PA 18322**