

Rogue Audio

Atlas

Vacuum Tube Power Amplifier

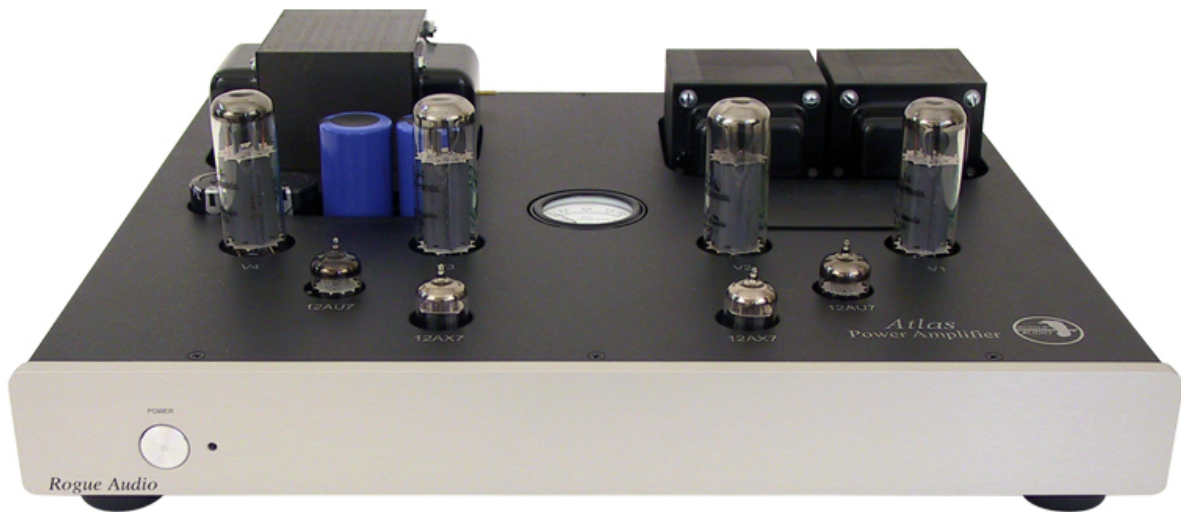

Owner's Manual

Rogue Audio, Inc.
3 Marian Lane
Brodheadsville, PA 18322

Issue date: 02/10/05

TABLE OF CONTENTS

1) Introduction	2
2) Unpacking the Atlas power amplifier	2
3) Installing the Atlas into your system	3
4) Operation of the amplifier	5
5) Setting the tube bias	5
6) Troubleshooting	7
7) Fuse values	8
8) Specifications	8
9) Product Registration and Warranty	9

INTRODUCTION

Congratulations on your purchase decision! We at Rogue Audio truly believe that our amplifiers provide the “smartest” value in high-end audio. If you have never owned a vacuum tube amplifier you will be thrilled by the silky-smooth sound and incredible detail that only a tube amplifier can provide. And with the Atlas amplifier, you can be sure that you are getting the very best in tube amplification. We at Rogue Audio are extremely proud of our products and want you to enjoy them to their fullest potential. So please, take the time to read through this short manual so that you can be confident that you have set up your amplifier properly.

UNPACKING THE ATLAS POWER AMPLIFIER

Tools required: none

WARNING - This amplifier uses voltages that could cause injury or death. Never open the amplifier while it is plugged in, and always wait at least one hour after turning the unit off to unplug and open the unit. *Lethal* voltages can remain in the electronics after the unit is unplugged.

The ATLAS amplifier has been painstakingly inspected for cosmetic flaws during and after assembly. In order not to damage the cosmetic appearance of your amplifier it is important that you follow the unpacking instructions carefully.

1. Remove the small corrugated box containing the tubes, spare fuses, and power cord.
2. Carefully lift the amplifier out of the box, and remove the foam pads and plastic bag.
3. Insert the tubes into the proper locations. Refer to Fig. 1 The output tubes will be marked per the figure. (ie V1, V2 etc.)
4. Save the packing materials. The packing materials and box have been carefully designed to protect your valuable equipment during shipping so you don't want to throw them away.

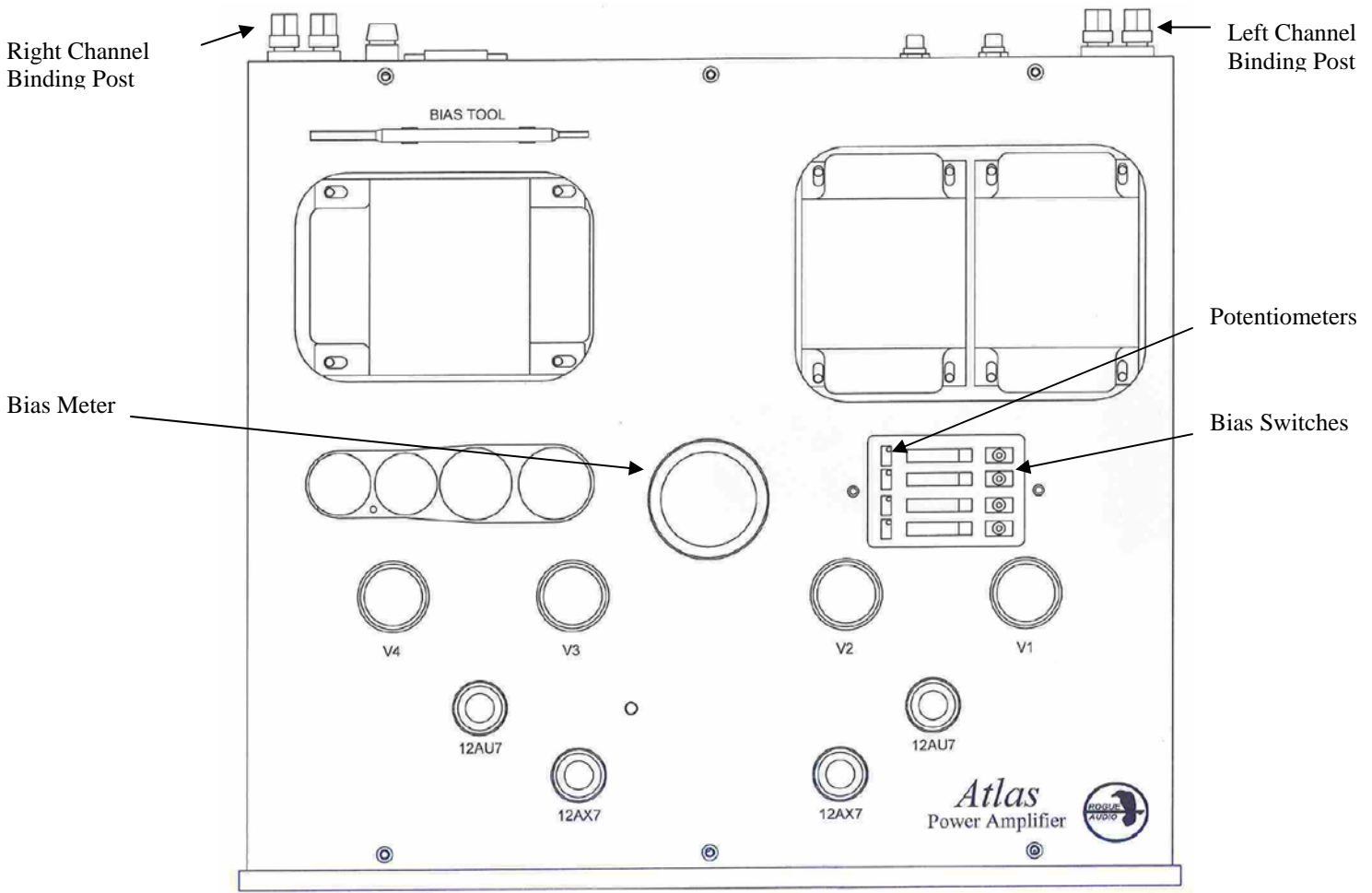

Figure 1 Tube and Deck Layout

INSTALLING THE ATLAS INTO YOUR SYSTEM

Connecting Atlas to the Loudspeakers:

The Atlas provides options for either 4 or 8 ohm speakers. The impedance selected will depend on the speakers used. Consult either the owner's manual for your speaker or your local dealer to determine the correct choice. The amplifier is factory set to 8 ohm.

To switch impedance setting:

- 1) Using a #2 philips screwdriver, remove the top cover or deck.
- 2) Using a 5/16" wrench, remove the outermost nut from the positive (red) binding post.
- 3) Remove the 8 ohm tap (green wire marked 8) from the binding post. Be careful to leave the black wire with heat shrink on the post.
- 4) Remove the polyurethane tubing from the unused 4 ohm wire (yellow) and lug.
- 5) Place the 4 ohm wire onto the binding post and replace the outer nut.
- 6) Place the polyurethane tubing on the 8 ohm wire and lug.

CAUTION – Do not operate the amplifier unless it is connected to a loudspeaker.

Connecting ATLAS to the preamplifier:

The input connections from the preamplifier are made via RCA jacks on the rear of the amplifier. See figure 2. Be sure to use high quality interconnect cables as they do make a difference

Note that if you have a variable output CD player you can drive the ATLAS with it directly.

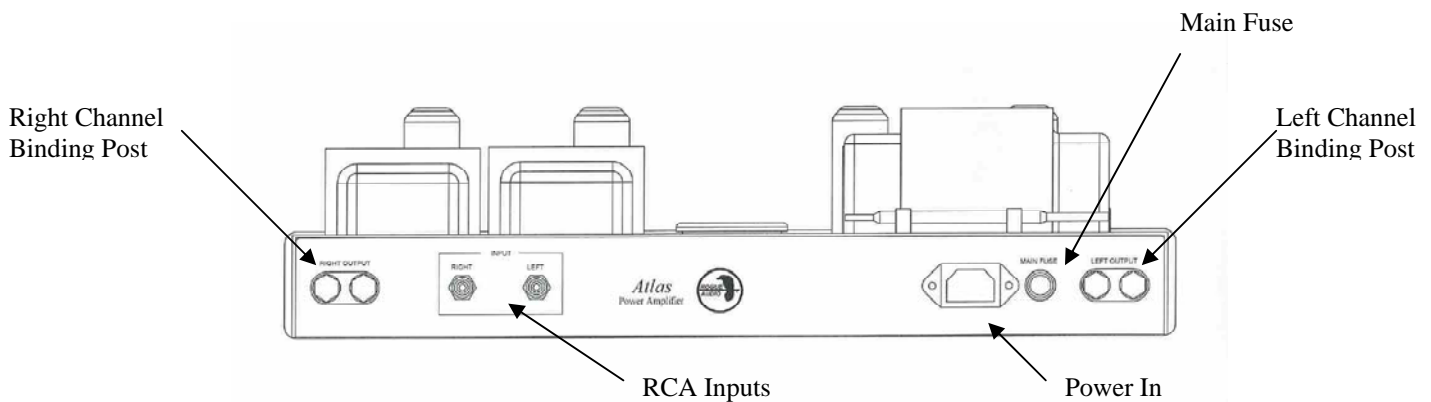

Figure 2. Rear panel layout

Connecting Atlas to the power outlet:

Connect the IEC end of the detachable power cord provided to the amplifier, and plug the opposite end into corresponding outlet. It is recommended that both the Atlas and your preamp are plugged into the same wall outlet if possible (perhaps using a power outlet strip). This is to avoid creating a ground loop.

Amplifier Location:

The Atlas is an open tube design and depends on natural convection flow patterns for proper cooling. To ensure proper cooling, the unit should be located in a position so that the airflow is not impeded. In addition, the unit should not be placed in an enclosed shelf, and should have a minimum of 6 inches of free space above and to the sides of it.

OPERATION OF THE AMPLIFIER

After all proper connections have been made, you are now ready to turn the Atlas amplifier on. The power on/off switch is on the front of the amp. Some preamplifiers and sources can generate dangerous transients that can damage loudspeakers. To avoid letting dangerous transients reach your loudspeakers turn your system on in the following order:

- 1) Turn on all sources (CD, tuner, etc.) that you will be using.
- 2) Turn on the preamplifier.
- 3) Wait until preamp has stabilized.
- 4) Power up Atlas amplifier
- 5) Select listening source and play music

When powering down your system turn the amplifier off first.

Note – **Important!** After turning off the amplifier, wait at least one minute to turn it back on. Do not turn it on then off and then on again in quick succession. Doing this will not allow the power supply to discharge between on/off cycling and may result in transient noises.

SETTING THE TUBE BIAS

Tools required: bias tool (provided with amplifier)

The output tubes (the big ones) need to be “biased” with a grid voltage that controls the flow of electrical current through the tube. Tube biasing on the Atlas amplifier has been designed to be both simple and effective. On some amplifiers biasing is done for two or more tubes simultaneously. With this method, the total current flowing through the group of tubes may be correct, but the current flow through any individual tube may vary significantly from the optimal value. With the Atlas amplifier the bias is set individually for each tube so that the correct operating point is assured. An added benefit to this approach is that, should a tube fail prematurely, the single tube can be replaced without having to purchase a matched set. Use the following procedure to set the tube bias:

WARNING – There are dangerous and potentially lethal voltages inside this amplifier. Do not touch any part of the amplifier other than as described below. If you are uncertain about any of these instructions, please contact your dealer and have them bias the amplifier for you.

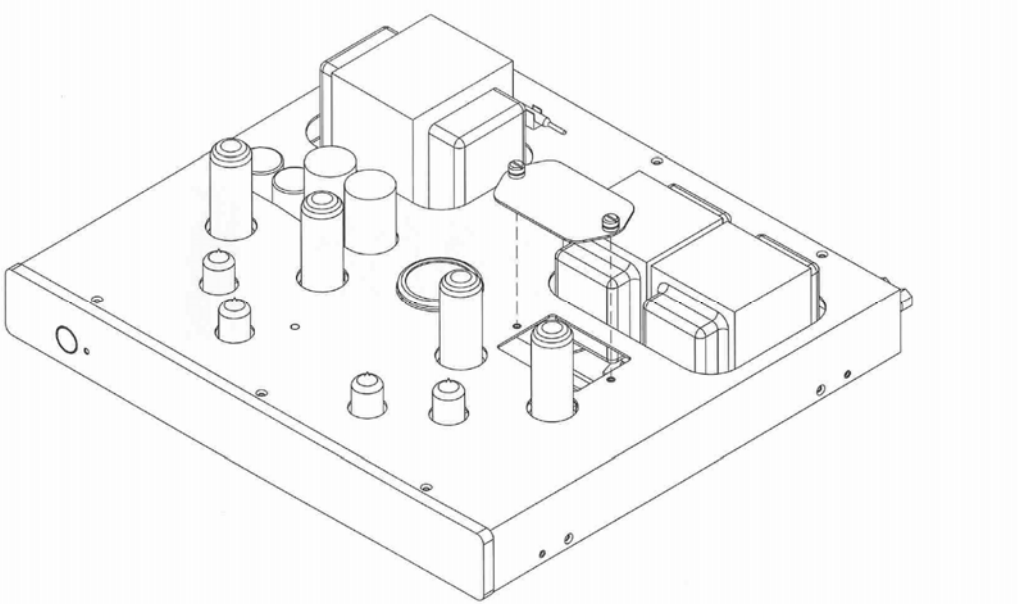

Figure 3. Removable hatchplate

- 1) Allow the amplifier to warm up for at least 30 minutes.
- 2) Turn the preamplifier volume completely off so that no signal is entering the amplifier
- 3) Loosen the 2 captive screws on the top hatch cover.
- 4) Remove the hatch cover.
- 5) The bias tool is snap attached to the top deck cover behind the power transformer. Refer to Figure 1.
- 6) Locate the toggle switches and associated small potentiometers (they are blue and have a small screw in the top). There are four, one for each output tube. Note the biasing meter.
- 7) Make sure that all of the toggle switches are pointed towards the meter (run position). Begin with any switch, moving the switch into the “set” position. You will see that the meter will rise up to show that the tube’s current is now flowing through the meter.
- 8) Using the bias tool, slowly turn the screw on the potentiometer that is adjacent to the switch until the bias meter reads ~ 35 milliamps (mA). Turn the screw clockwise to lower the bias and counterclockwise to raise the bias. Note that there are two ends on the bias tool. Using the end with the recessed screwdriver will greatly facilitate this operation.

- 9) Flip the switch back into the “run” position thus disengaging the tube from the meter circuit.
- 10) Repeat the above steps for each of the tubes in both channels.

As it is a quick operation, the tube bias should be checked on a regular basis. Note that the bias will change slightly on a day to day basis as the wall voltage fluctuates. Constant biasing will wear out the bias potentiometers prematurely so do not adjust the bias unless it is more than 4-5 mA from the correct setting.

TROUBLESHOOTING

Speaker Hum – If hum can be heard from more than a few inches from the loudspeaker, there is probably a ground loop. Be sure to have the amp and preamp plugged into the same outlet if possible. If this fails to cure the hum, call customer service at Rogue Audio for further advice.

Tube will not bias – If the meter provides a reading but the tube will not bias, the tube is probably bad. If no meter reading can be attained, check the fuse (1/4 Amp slow blow). If the fuse is bad, replace the fuse and then set the bias. If the bias will not maintain itself and the fuse blows again, the tube should be replaced.

Bias Meter reading is too high – Check that you do not have two of the bias switches turned on.

Output sounds distorted - Check the bias on the output tubes to ensure that the tubes are operating properly.

FUSE VALUES

Main fuse located on rear panel (1) – 5 Amp slow blow

Tube Fuses (4) – 1/4 Amp slow blow

Power Supply Fuse on PCB (1) – 3/4 Amp slow blow

SPECIFICATIONS

output power	55 WPC
frequency response	5Hz – 50 kHz ± 1dB
THD	< 0.1% typ, < 1% at rated power
input sensitivity	1.0 V RMS
dimensions	18" W x 17" D x 5.5" H
weight	50 pounds (25 Kg)
shipping weight	55 lbs (27 Kg)
power requirements	115/230V - 50/60Hz

OWNER AND WARRANTY REGISTRATION FORM

Included with this manual is an Owner and Warranty Registration Form. Please take a minute to fill out this card and return it to Rogue Audio. This card must be returned within 30 days of purchase to validate the warranty.

LIMITED WARRANTY

Warranty Period

This product has been manufactured under the highest standards of quality and workmanship. Rogue Audio Inc. (hereinafter "Rogue Audio") warrants this product against defects in material or workmanship as follows:

With the exception of vacuum tubes, Rogue Audio warrants to the original purchaser of this product all parts of this product against defects in material and workmanship for a period of three years from the date of retail purchase. Rogue Audio warrants the vacuum tubes for a period of six months from the date of retail purchase. Any defective parts will be replaced free of charge, excluding shipping and handling.

Proof of purchase in the form of a bill of sale or recited invoice which indicates that the product is within the warranty period must be presented to obtain warranty service. Rogue Audio suggests that the purchaser retain the dealer's bill of sale as evidence of the date of retail purchase.

What's Not Covered

This warranty does not cover cosmetic damage or any damage that results from product misuse, product abuse, installation error, connection to an improper voltage supply, accident, improper maintenance, alterations, modifications not authorized in writing by Rogue Audio, lightning, power surges, or acts of God. Use of any other than Rogue Audio factory parts may void this warranty.

This warranty does not cover the cost of parts and labor which would be otherwise provided without charge under this warranty, obtained from any source other than Rogue Audio.

This warranty applies only to consumer use of this product and does not cover any product that is used in any trade or business, or in an industrial or commercial application.

This warranty applies only to the original purchaser of this product when purchased from an Authorized Rogue Audio dealer.

This warranty is valid only in the United States.

YOUR RIGHTS

ROGUE AUDIO LIMITS ITS OBLIGATIONS UNDER ANY IMPLIED WARRANTIES UNDER STATE LAWS TO A PERIOD NOT TO EXCEED THE WARRANTY PERIOD. SOME STATES DO NOT ALLOW LIMITATIONS ON HOW LONG AN IMPLIED WARRANTY LASTS, AND SOME STATES DO NOT ALLOW THE EXCLUSION OR LIMITATION OF INCIDENTAL OR CONSEQUENTIAL DAMAGES, SO THE ABOVE LIMITATIONS OR EXCLUSIONS MAY NOT APPLY TO YOU. THIS WARRANTY GIVES YOU SPECIFIC LEGAL RIGHTS, AND YOU MAY HAVE OTHER RIGHTS WHICH MAY VARY FROM STATE TO STATE.

To Obtain Service

To obtain service, you must contact Rogue Audio and obtain a return authorization number. The product must be delivered to Rogue Audio in its original packaging prepaid at the following address:

**Rogue Audio Inc.
3 Marian Lane
Brodheads ville, PA 18322**