

## TABLE OF CONTENTS

1) Introduction_____	2
2) Unpacking your preamplifier_____	2
3) Installing the preamp into your system_____	3
4) Operation of your preamplifier_____	6
5) Troubleshooting _____	8
6) Registration of your preamplifier_____	8
8) Fuse values_____	9
9) Specifications_____	9
10) Product Registration and Warranty_____	10

## INTRODUCTION

Congratulations on your purchase decision! We at Rogue Audio truly believe that our preamplifiers provide the “smartest” value in high-end audio. If you have never owned a vacuum tube preamplifier you will be thrilled by the silky-smooth sound and incredible detail that only a tube preamplifier can provide. And with the Hera and Athena preamplifiers, you can be sure that you are getting the very best in tube amplification. We at Rogue Audio are extremely proud of our products and want you to enjoy them to their fullest potential. So please, take the time to read through this short manual so that you can be confident that you have set up your preamplifier properly.

## UNPACKING YOUR PREAMPLIFIER

**Tools required:** none

**WARNING - This preamplifier uses voltages that could cause injury or death. Never open the preamplifier while it is plugged in, and always wait at least one hour after turning the unit off to unplug and open the unit. *Lethal* voltages can remain in the electronics after the unit is unplugged.**

Your new preamplifier has been painstakingly inspected for cosmetic flaws during and after assembly. In order not to damage the cosmetic appearance of your preamplifier it is important that you follow the unpacking instructions carefully.

1. Open the shipping carton and remove the remote control, power cord and power supply cables from the corners of the carton.
2. Carefully lift the preamplifier out of the carton, and remove the foam pads and plastic bag.
3. Carefully lift the power supply out of the carton, and remove the foam pads and plastic bag.
4. Save the packing materials. The packing materials and box have been carefully designed to protect your valuable equipment during shipping so you don't want to throw them away.

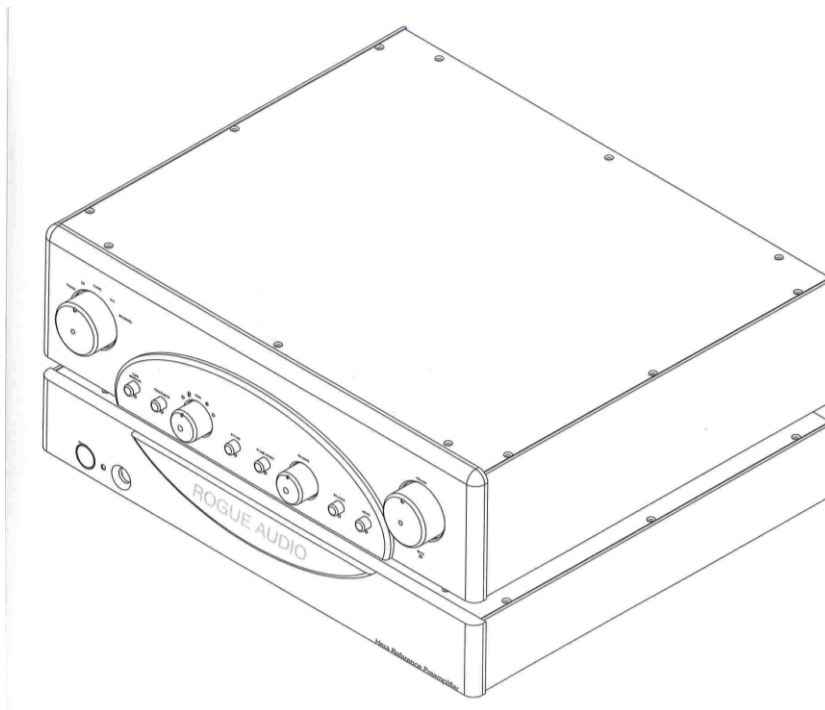

Figure 1.

## INSTALLING THE PREAMPLIFIER INTO YOUR SYSTEM

### Connecting the Power Supply to the Preamplifier

Your preamplifier is a two box preamplifier, where the power supply and AC/DC conversion is placed in a separate box to lower the noise floor of the unit. The Hera preamplifier chassis is designed to sit directly on top of the power supply chassis, see Figure 1. The two boxes may be placed on different racks if this is more convenient in your system and optional longer cables are available from Rogue Audio if needed. If you have an Athena, the separate power supply box should be placed away from the main chassis. There are three cables provided for connecting the power supply to the preamplifier. These are four, five and six conductor cables. See Figure 2. These cables have both male and female ends on them. Connect the four conductor cable to the power supply using the male end of the cable and then connect the cable to the preamplifier using the female end of the cable. Do the same for the five and six conductor cables (Note that these cables are permanently attached to the power supply on the Athena). **It is important to make these connections before connecting the power cord to the wall outlet.** Note that certain critical portions of the Hera circuitry remain energized even when the unit is turned off so never disconnect any of these cables while the power supply is plugged into a power outlet.

**Warning – Never disconnect any of the three cables while the power supply is plugged into a power outlet. You will damage the preamplifier**

When moving the preamp always turn off the power, wait 15 minutes and then unplug the preamp from the power outlet before disconnecting any of the three rear cables.

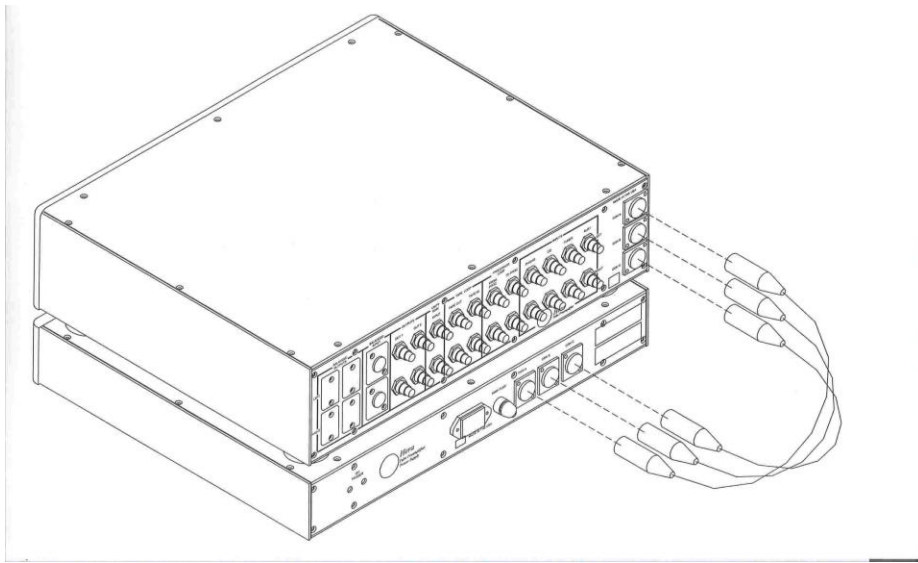

Figure 2

**Connecting the power supply to the power outlet:**

Connect the IEC end of the detachable power cord to the Power Supply, shown in Figure 3. Plug the opposite end of the power cord into an appropriate power outlet. It is recommended that both the preamplifier and power amplifier are plugged into the same wall outlet if possible (perhaps using a power outlet strip) in order to avoid creating a ground loop.

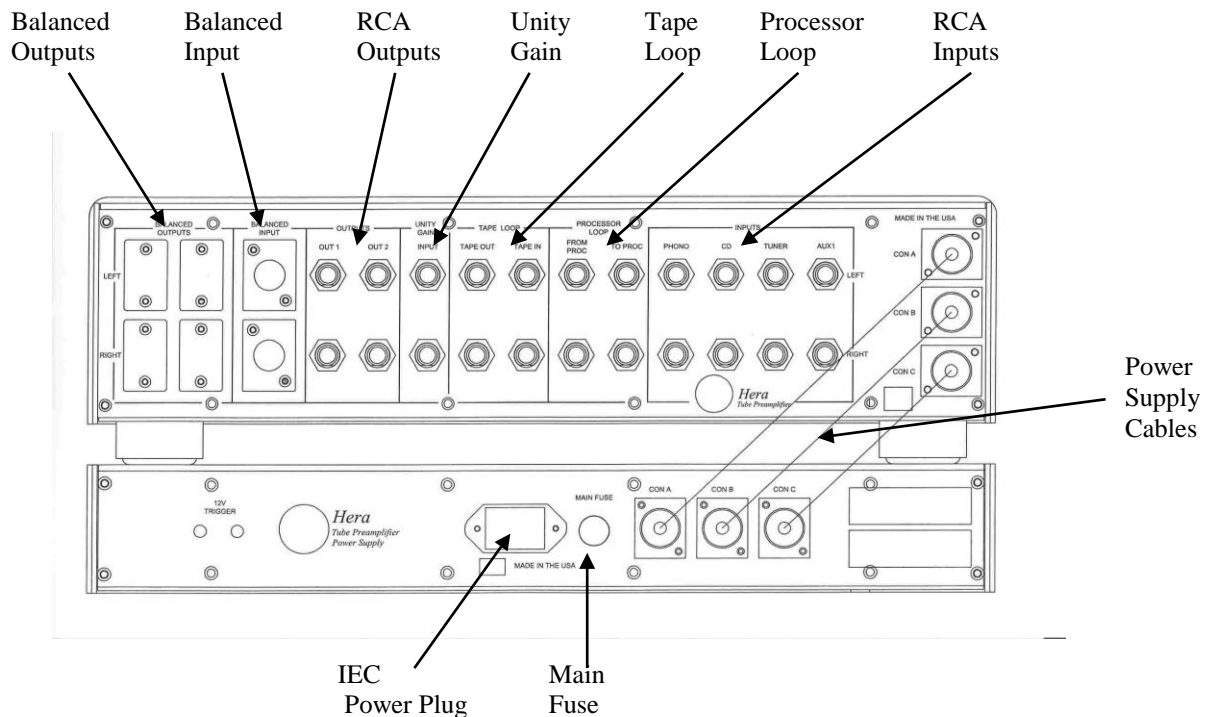

Figure 3

**Connecting the preamplifier to two channel (Stereo) sources:**

Connections are made on the rear panel of the preamplifier and are shown in Figure 3. The input connections for two channel source material are made via RCA Jacks or XLR Balanced Connectors. There are 4 RCA line level inputs:

Phono (for an external phono preamp), CD, Tuner, and AUX 1. There is also one pair of Balanced XLR inputs.

### **Connecting multi channel sources using the Unity Gain Input:**

Your preamplifier features a unity gain bypass allowing you to integrate your two channel music systems into a multichannel home theater system. This conveniently enables you to share speakers and amps between systems without switching interconnect or speaker cables. In this configuration the preamplifier is used with two channel sources such as CD Players, turntables, tuners etc, while a separate processor or multi channel receiver is used with multichannel sources such as DVD movies. Simply connect the left and right front outputs from your processor to the unity gain inputs on the preamp. These inputs route the home theater signal directly to the power amp completely bypassing the active circuitry in the Hera or Athena. To activate this unity gain input, the bypass switch on the front of the preamplifier must be pushed in (see Figure 3). Once this switch is on, all other inputs are deactivated and the preamplifier is in bypass mode. Note that if the preamplifier is turned off it automatically goes into bypass mode.

### **Connecting an audio processor to the Hera or Athena:**

Both preamplifiers feature a processor loop which allows processors (equalizer, room correction, bass enhancement, etc..) to be used. There are two sets of RCA jacks on the rear of the preamp for connecting to/from a processor. When the processor button is pushed in a blue LED below the button will light indicating that the source signal is going through the processor. With the button out the signal bypasses the processor. Note that if no processor is connected and the button is pushed in then the signal is interrupted and there will be no output from the preamplifier.

### **Connecting a tape or CD recorder to the preamplifier:**

Your preamplifier features a buffered tape loop and tape monitor for recording from other sources and for monitoring the recording as it is being made. The buffered tape output prevents “loading down” of the preamp by the recording equipment thus providing a higher level of fidelity in the recording process as well as the monitored playback. Connect the output jacks from the recording device to the “Tape In” jacks on the back of the preamp. Connect the “Tape Out” jacks on the preamplifier to the input jacks of the recording device. Note that if the Tape Monitor button is pushed in that the musical source will be the output from the recording device.

### **Connecting the preamplifier to the power amplifier:**

There are two RCA outputs and two Balanced XLR outputs. These are used to connect the Preamplifier to the Power Amplifier in your system. Note that the output in balanced mode is 3dB higher than for single ended mode.

### **Connecting a subwoofer:**

A second set of both RCA and XLR outputs are provided that can be used for connecting a subwoofer to your preamp. The signal to these outputs is identical to the signal going to the power amp and varies with the volume control. Note that these outputs can also be used for biamping or running a second power amp located elsewhere.

## OPERATION OF THE PREAMPLIFIER

### Powering up the System:

After all proper connections have been made, you are now ready to turn the preamplifier on. If you have a Hera, the power on/off switch is on the front of the power supply. The power switch on the Athena is located on the lower right of the faceplate. Your preamplifier features an automated sequential soft-starting mode to prolong tube life as well as to suppress turn-on transients. When the unit is first turned on, the tube heaters are energized. After approximately twenty seconds, the high voltage supply is turned on and after an additional twenty seconds the outputs are disconnected from ground and the preamp is ready for operation. After turning on the preamplifier, turn on the power amplifier and source material and you are ready for listening. Note that critical portions of the Hera remain energized even with the power button in the off position. The first time that your preamp is turned on (and anytime it is unplugged from the power outlet) it is best to let it idle for a few minutes before playing music. This allows these portions of the circuitry to reach optimum operating parameters.

**NOTE - This unit will not play for approximately 40-60 seconds after power on while the preamp goes through its sequential start-up.**

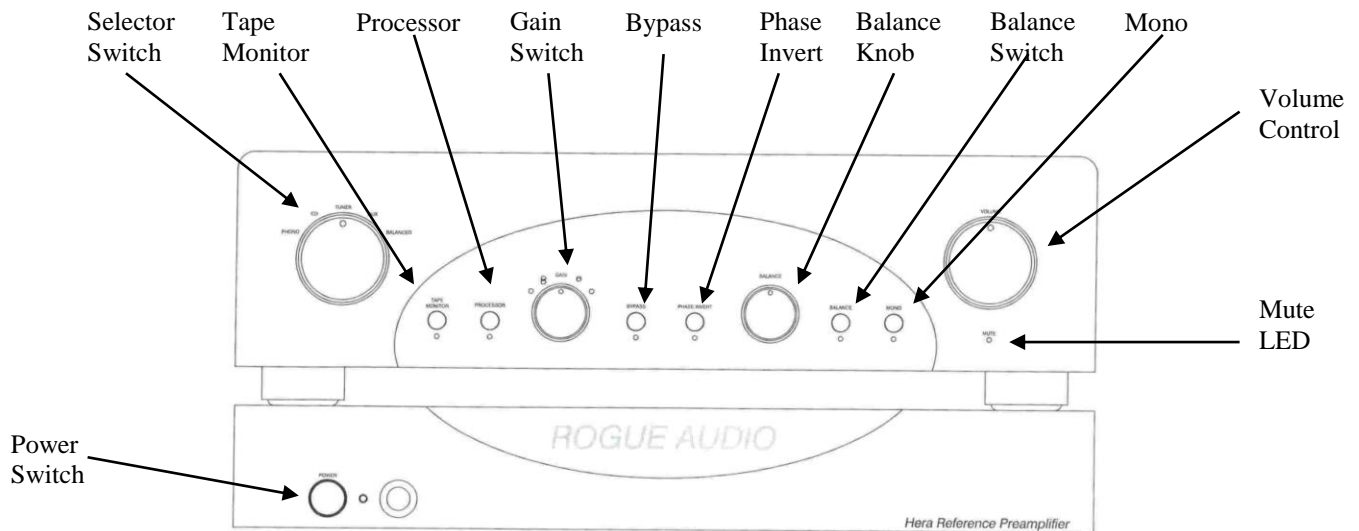

Figure 4

### Switches and Controls:

Your preamplifier is equipped with extremely high quality volume, balance, source, and gain switches. It also has power, tape monitor, processor, bypass, phase invert, balance, and mono button (Hera only). See Figure 4. In addition the preamp is supplied with a remote volume control and mute feature.

## **Knob Controls**

- Volume - The preamp employs a proprietary stepped attenuator that is connected to a DC motor via a miniature slipper clutch. Volume adjustments are made in approximately 2dB increments.
- Gain – The gain knob changes the overall range in which the volume control operates. This permits the user to fine tune the volume control so that full use of the stepped attenuator is achieved. The center position is considered nominal for single ended operation.
- Balance - full left and right channel attenuation. The balance control is completely out of the audio circuit unless the balance button is pushed in.
- Source – selects source material (Phono, CD, Tuner, AUX1, and Balanced inputs)

## **Pushbutton Switches**

- Power – on/off operation, on the Power Supply. When activated the blue LED under the switch will light.
- Tape Monitor - activates the tape loop. When activated the blue LED under the switch will light. The tape monitor features a buffered tape output eliminating potential sonic degradation of the signal while taping. When pushed in, the input to the preamplifier is sourced from the taped material.
- Processor - activates the processor loop. When activated the blue LED under the switch will light.
- Bypass – As explained in the Installation Section, the bypass switch routes the unity gain input directly to the amplifier outputs effectively bypassing the preamplifier. When activated the blue LED under the switch will light.
- Phase Invert – switches the phase of the output of the preamplifier. When activated the blue LED under the switch will light. Note that correcting the phase of some recordings may provide better fidelity.
- Balance – activates the balance control. If this switch is not depressed the balance potentiometer is not in the system and will not work. When activated a blue LED under the switch will be on and the balance control will be active
- Mono – combines left and right channels. When activated the blue LED under the switch will be lit.

## **12Volt Triggers (Hera only):**

The Hera has two 12V trigger (outputs) located on the rear of the power supply chassis. If you have other equipment with triggered inputs you can use the Hera to turn them on and off. The 12V triggers are turned on when the Hera is powered up and turned off when the Hera is powered down.

## **Remote Controls**

- Remote Volume Control – Your preamplifier is equipped with a stepped attenuator remote volume control feature. The volume may be adjusted manually using the knob on the front panel, or by using the remote control provided.
- Remote Mute - Your preamplifier is equipped with a remote mute control. When the preamp is muted, a red LED will light in the lower right corner under the volume knob.

## TROUBLESHOOTING

### *Speaker Hum*

- If hum can be heard from more than a few inches from the loudspeaker, there is probably a ground loop. Be sure to have the amp and all sources plugged into the same outlet if possible. If this fails to cure the hum, call customer service at Rogue Audio for further advice 570-992-9901.

### *Unit does not turn on*

- Check that the power cord connection is secure

### *Unit does not play*

- Check that the interconnects are connected to the proper input or output.
- Check that the interconnects are connected securely.
- Processor button is pushed in with no processor or with the processor turned off.
- Tape monitor button is pushed in with no signal.

### *One channel does not play*

- Check that the balance pot is centered.
- Check that the tubes are seated correctly and securely

For further problems, please call Rogue Audio Technical Support at 570-992-9901.

## OWNER AND WARRANTY REGISTRATION FORM

Included with this manual is an Owner and Warranty Registration Form. Please take a minute to fill out this card and return it to Rogue Audio. This card must be returned within 30 days of purchase to validate the warranty.



## FUSE VALUES

One 5A slow Blow Type Fuse located on rear of power supply box

## HERA SPECIFICATIONS

Tube Complement	Eight 6H30P tubes
Frequency Response	1Hz – 250KHz +/- 3dB
THD	<0.1%
Gain Stage	12dB SE, 15dB Balanced
Rated Output	1V RMS
Output impedance	150 Ohms
Maximum Output	25 Peak
Main Unit Dimensions	18¼ x 15¼ x 5½
Power Supply Dimensions	18¼ x 15¼ x 3½
Main Unit Weight	30 Lb
Power Supply Weight	7 Lb
Shipping Weight	45 Lb
Power Requirements	115/230V – 50/60Hz

## ATHENA SPECIFICATIONS

Tube Complement	Four 6H30P tubes
Frequency Response	1Hz – 250KHz +/- 3dB
THD	<0.1%
Gain Stage	12dB SE, 15dB Balanced
Rated Output	1V RMS
Output impedance	250 Ohms
Maximum Output	25 Peak
Main Unit Dimensions	18¼ x 15¼ x 3½
Power Supply Dimensions	18¼ x 15¼ x 5½
Main Unit Weight	28 Lb
Power Supply Weight	8 Lb
Shipping Weight	45 Lb
Power Requirements	115/230V – 50/60Hz

## LIMITED WARRANTY

### Warranty Period

This product has been manufactured under the highest standards of quality and workmanship. Rogue Audio Inc. (hereinafter "Rogue Audio") warrants this product against defects in material or workmanship as follows:

With the exception of vacuum tubes, Rogue Audio warrants to the original purchaser of this product all parts of this product against defects in material and workmanship for a period of three years from the date of retail purchase. Rogue Audio warrants the vacuum tubes for a period of six months from the date of retail purchase. Any defective parts will be replaced free of charge, excluding shipping and handling.

Proof of purchase in the form of a bill of sale or recited invoice which indicates that the product is within the warranty period must be presented to obtain warranty service. Rogue Audio suggests that the purchaser retain the dealer's bill of sale as evidence of the date of retail purchase.

### What's Not Covered

This warranty does not cover cosmetic damage or any damage that results from product misuse, product abuse, installation error, connection to an improper voltage supply, accident, improper maintenance, alterations, modifications not authorized in writing by Rogue Audio, lightening, power surges, or acts of God. Use of any other than Rogue Audio factory parts may void this warranty.

This warranty does not cover the cost of parts and labor which would be otherwise provided without charge under this warranty, obtained from any source other than Rogue Audio.

This warranty applies only to consumer use of this product and does not cover any product that is used in any trade or business, or in an industrial or commercial application.

This warranty applies only to the original purchaser of this product when purchased from an Authorized Rogue Audio dealer.

This warranty is valid only in the United States.

### YOUR RIGHTS

ROGUE AUDIO LIMITS ITS OBLIGATIONS UNDER ANY IMPLIED WARRANTIES UNDER STATE LAWS TO A PERIOD NOT TO EXCEED THE WARRANTY PERIOD. SOME STATES DO NOT ALLOW LIMITATIONS ON HOW LONG AN IMPLIED WARRANTY LASTS, AND SOME STATES DO NOT ALLOW THE EXCLUSION OR LIMITATION OF INCIDENTAL OR CONSEQUENTIAL DAMAGES, SO THE ABOVE LIMITATIONS OR EXCLUSIONS MAY NOT APPLY TO YOU. THIS WARRANTY GIVES YOU SPECIFIC LEGAL RIGHTS, AND YOU MAY HAVE OTHER RIGHTS WHICH MAY VARY FROM STATE TO STATE.

### To Obtain Service

To obtain service, you must contact Rogue Audio and obtain a return authorization number. The product must be delivered to Rogue Audio in its original packaging prepaid at the following address:

**Rogue Audio Inc.  
3 Marian Lane  
Brodheadsville, PA 18322**